

SAFETY AIR JUMPING CUSHION

Safety Air Jumping Cushion

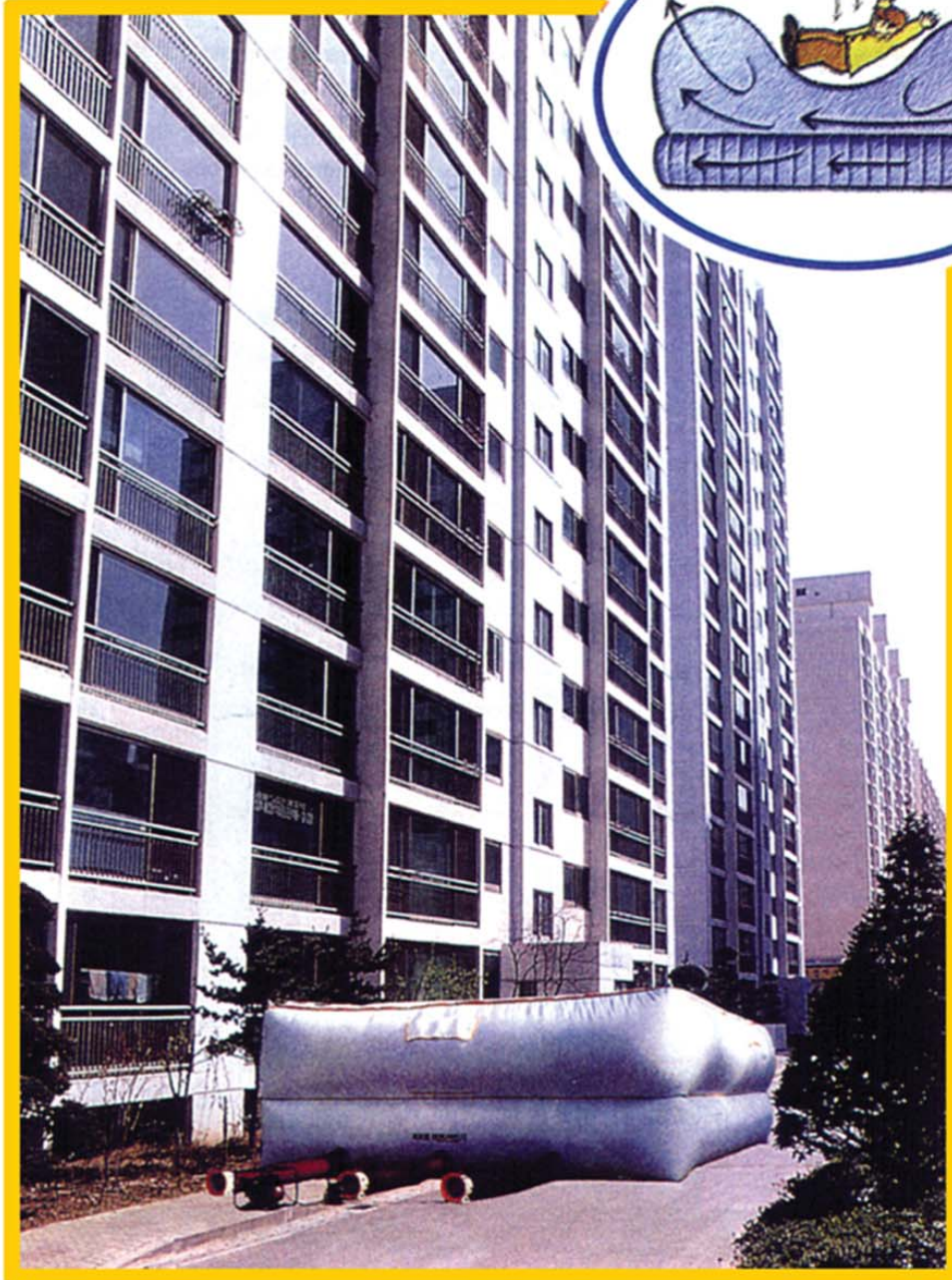

ileri
Defense, SAR, Security, Medical
Industry & Trading Co. Ltd.

Head Office: ATB İş Merkezi, C Blok No: 82, Macunköy, Ankara - TURKEY
Phone: +90 - 312 - 397 4669
Fax: +90 - 312 - 397 3646
E-mail: ileri@ilerisavunma.com
Web: www.ilerisavunma.com

GENERAL INFORMATION ABOUT AIR CUSHIONS

Safety Air Jumping Cushions are made of 2 or more chambers depending on the model. The blowers first fill the lower chamber and then continues to fill the upper chamber. Duration of complete fill depends on the size and takes approximately between 60 seconds to 5 minutes.

In order to achieve a soft landing, the air cushions have air outlets on all sides. The fans continuously fill the cushion and the overpressure air leaks from these outlets. At the moment of landing, these outlets also let the air out to absorb the shock and provide a soft landing, prevent bouncing.

The cushion is made of abrasionproof special polyester coated fire-retardant 1000 denier fabric. Fabric connections are double seamed to provide extra strength.

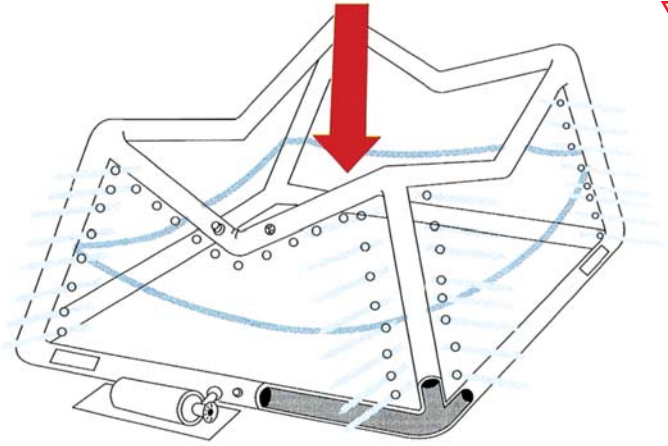

Compressed Air Cylinder Type

ELECTRICAL FAN TYPE

The cushion is filled continuously by electric engine blowers. The electrical blowers (fans) are powered by mains supply or a generator.

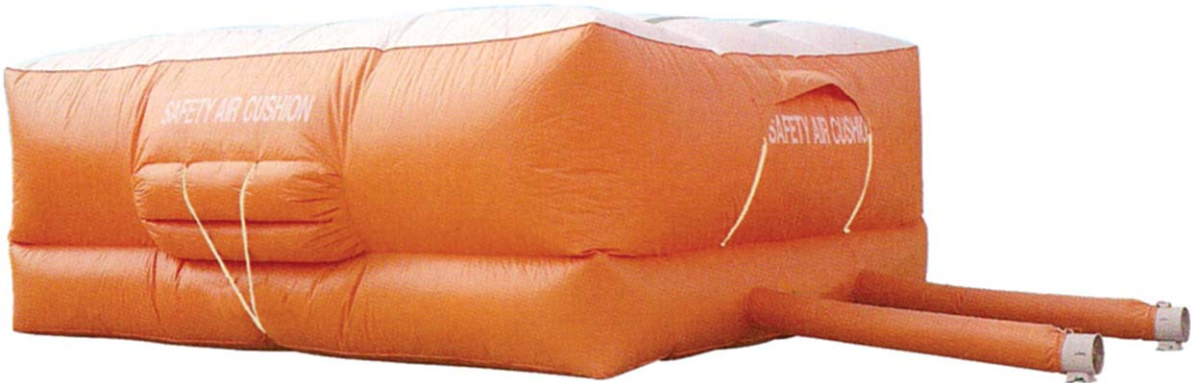

Model	SAC50-E	SAC70-E	SAC100-E	SAC150-E
Size (cm)	450x500x250	450x600x250	600x800x300	700x1000x350
Jumping Height	15 m	21 m	30m	45 m
Fan	1x400 W	1x400 W	2x400 W	2x750 W
Inflation Dur.	70 sec	120 sec	180 sec	300 sec
Reinflation Dur.	13 sec	15 sec	40 sec	50 sec
Weight (cpl.)	75 kg	100 kg	170 kg	220 kg

COMPRESSED AIR CYLINDER TYPE

Only the cushion frame is filled with compressed air from a compressed air cylinder. No power source needed. Inflates in 20-150 seconds, re-inflates in 3-12 seconds depending on the size. For higher safety, 3 chamber model is available for all sizes.



Model	SAC50-C	SAC60-C	SAC70-C	SAC100-C	SAC150-C
Size (cm)	370x370x170	450x450x230	450x600x250	600x800x300	700x1000x350
Jumping Height	15 m	18 m	21 m	30m	45 m
Inflation Cylinders	1x8 lt.	1x8 lt.	1x10,2 lt.	2x10,2 lt.	2x10,2 lt.
Inflation Duration	20 sec	25 sec	30 sec	50 sec	100 sec
Reinflation	3 sec	4 sec	5 sec	7 sec	15 sec
Weight	70 kgs	85 kgs	120 kgs	170 kgs	250 kgs

UPPER & LOWER AIR SUPPLIED CUSHION

In this model, upper and lower chambers are inflated by separate fans. It can be used at heights up to 10 floors.

The cushion is made of self extinguishing, anti-acid, highly tear and abrasion resistant material.

It can be set up with only 3 people within 5 minutes. It takes less than 1 minute to inflate the cushion once the fans are switched on.

The product has ISO certification. The fans are rated IP55 and the sockets IP67. The system can be used in rainy weather also.



Model	LJ100A	LJ35A
Size (cm)	600x760x275	450x300x275
Jumping Height	10 Floors	4 Floors
Fans	750W+550W	230W+300W
Inflation Duration	70 sec	50 sec
Weight	220 kg	70 kg

